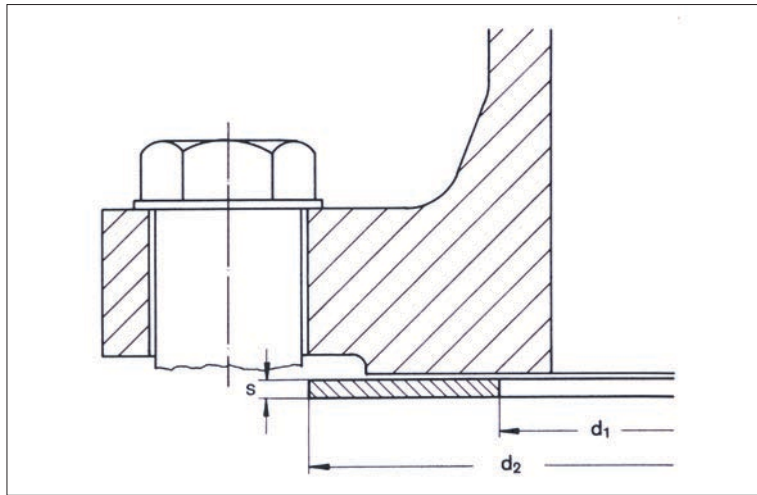

## Gaskets according to DIN 2690 for raised-face flanges as well as according to DIN EN 1514-1, Form IBC

**Material:**

KLINGER gasket material

**Specification:**

1. Gasket DIN 2690,  
PN 40, DN 65  
made of KLINGERSIL® C-4400,  
s = 1.5 mm
2. Gasket DIN EN 1514-1,  
Form IBC, PN 16, DN 250  
made of KLINGERSIL® C-4430,  
s = 2.0 mm

**Measures in mm**

DN	d <sub>1</sub>		d <sub>2</sub> for PN													
			1 and 2,5		6		10		16		25		40			
	DIN 2690	DIN 1514	DIN 2690	DIN 1514	DIN 2690	DIN 1514	DIN 2690	DIN 1514	DIN 2690	DIN 1514	DIN 2690	DIN 1514	DIN 2690	DIN 1514		
4	6	—	—	—	—	—	—	—	—	—	—	30	—	—	—	
6	10	—	28	—	28	—	38	—	38	—	38	—	38	—	38	—
8	14	—	33	—	33	—	43	—	43	—	43	—	43	—	43	—
10	18	18	38	39	38	39	45	46	45	46	45	46	45	46	45	46
15	22	22	43	44	43	44	50	51	50	51	50	51	50	51	50	51
20	28	27	53	54	53	54	60	61	60	61	60	61	60	61	60	61
25	35	34	63	64	63	64	70	71	70	71	70	71	70	71	70	71
32	43	43	75	76	75	76	82	82	82	82	82	82	82	82	82	82
40	49	49	85	86	85	86	92	92	92	92	92	92	92	92	92	92
50	61	61	95	96	95	96	107	107	107	107	107	107	107	107	107	107
60*	—	72	—	106	—	106	—	117	—	117	—	117	—	117	—	117
65	77	77	115	116	115	116	127	127	127	127	127	127	127	127	127	127
80	90	89	132	132	132	132	142	142	142	142	142	142	142	142	142	142
100	115	115	152	152	152	152	162	162	162	162	168	168	168	168	168	168
125	141	141	182	182	182	182	192	192	192	192	195	194	195	194	195	194
150	169	169	207	207	207	207	218	218	218	218	218	225	224	225	224	224
(175)	195	—	237	—	237	—	248	—	248	—	248	—	255	—	267	—
200	220	220	262	262	262	262	273	273	273	273	273	285	284	292	290	290
250	274	273	318	317	318	317	328	328	330	329	342	340	353	352	352	352
300	325	324	373	373	373	373	378	378	385	384	402	400	418	417	417	417
350	368	356	423	423	423	423	438	438	445	444	458	457	475	474	474	474
400	420	407	473	473	473	473	490	489	497	495	515	514	547	546	546	546
450	470	458	528	528	528	528	540	539	557	555	565	564	572	571	571	571
500	520	508	578	578	578	578	595	594	618	617	625	624	628	628	628	628
600	620	610	680	679	680	679	695	695	735	734	730	731	745	747	747	747
700	720	712	785	784	785	784	810	810	805	804	830	833	850	—	—	—
800	820	813	890	890	890	890	915	917	910	911	940	942	970	—	—	—
900	920	915	990	990	990	990	1015	1017	1010	1011	1040	1042	1080	—	—	—
1000	1020	1016	1090	1090	1090	1090	1120	1124	1125	1128	1150	1154	1190	—	—	—
1100	—	1120	—	—	—	—	—	1231	—	1228	—	1254	—	—	—	—
1200	1220	1220	1290	1290	1305	1307	1340	1341	1340	1342	1360	1364	1395	—	—	—
1400	1420	1420	1490	1490	1520	1524	1545	1548	1540	1542	1575	1578	1615	—	—	—
1500*	—	1520	—	—	—	—	—	1658	—	1654	—	1688	—	—	—	—
1600	1620	1620	1700	1700	1720	1724	1770	1772	1760	1764	1795	1798	1830	—	—	—
1800	1820	1820	1900	1900	1930	1931	1970	1972	1960	1964	2000	2000	—	—	—	—
2000	2020	2020	2100	2100	2135	2138	2180	2182	2165	2168	2230	2230	—	—	—	—
2200	2220	2220	2305	2307	2345	2348	2380	2384	2375	—	—	—	—	—	—	—
2400	2420	2420	2505	2507	2555	2558	2590	2592	2585	—	—	—	—	—	—	—
2600	2620	2620	2705	2707	2760	2762	2790	2794	2785	—	—	—	—	—	—	—
2800	2820	2820	2920	2924	2970	2972	3010	3014	—	—	—	—	—	—	—	—
3000	3020	3020	3120	3124	3170	3172	3225	3228	—	—	—	—	—	—	—	—
3200	3220	3220	3320	3324	3380	3382	—	—	—	—	—	—	—	—	—	—
3400	3420	3420	3520	3524	3590	3592	—	—	—	—	—	—	—	—	—	—
3600	3620	3620	3730	3734	3800	3804	—	—	—	—	—	—	—	—	—	—
3800	3820	3820	3930	3931	—	—	—	—	—	—	—	—	—	—	—	—
4000	4020	4020	4130	4131	—	—	—	—	—	—	—	—	—	—	—	—

\* Only for flanges made of cast iron

Subject to technical alterations.

Status 9/2000